

# No. 8200 Drawer Slide Installation Instructions

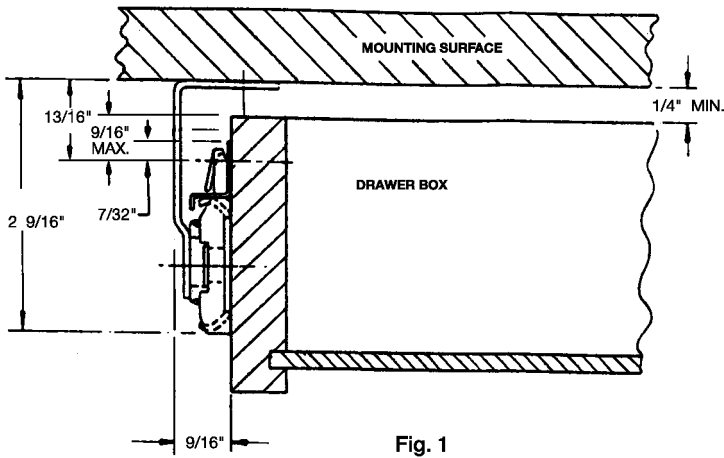

Fig. 1

## Step 1.

Determine right hand case member from left hand case member by locating the front molded lock (See Fig. #2). With the front molded lock pointing towards you, identify whether the slide is left hand or right hand by making sure the brackets turn inward.

## Step 2.

Mount case members to the mounting surface using Fig. #1 for key dimensions. Mounting brackets are slotted for installation adjustment. Note Fig. #3. The front bracket mounting hole is centered  $2 \frac{1}{32}$ " from the front edge of the slide. Therefore, if a flush drawer front is desired, center the front mounting bracket  $2 \frac{1}{32}$ " + drawer front thickness, from the front edge of the mounting surface.



Top

Fig. #2

Bottom

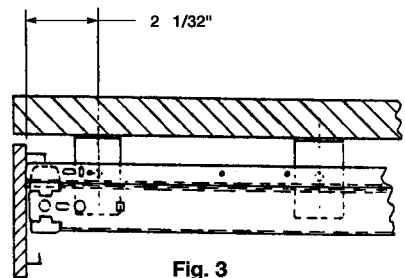
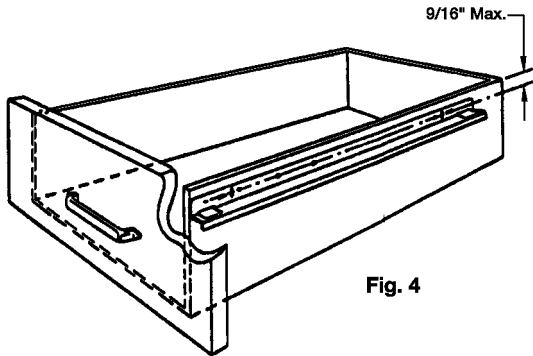

Fig. 3

**Step 3.**

Fasten drawer channels (non-handed) flush with the back of the drawer front as show in Fig. #4. Screw holes for drawer members *must not* be drilled any lower than  $\frac{9}{16}$ " from the top edge of the drawer side. This will provide a minimum required clearance of  $\frac{1}{4}$ " between the drawer sides and mounting surface for drawer insertion. (See Fig. #5)

**Step 4.**

Pull case members all the way out. Insert drawer by fitting drawer members under the case member hooks and snapping down over the front lock. (See Fig. #5)

**Step 5.**

To release the drawer, push the front lock in towards the drawer, lift and remove.

