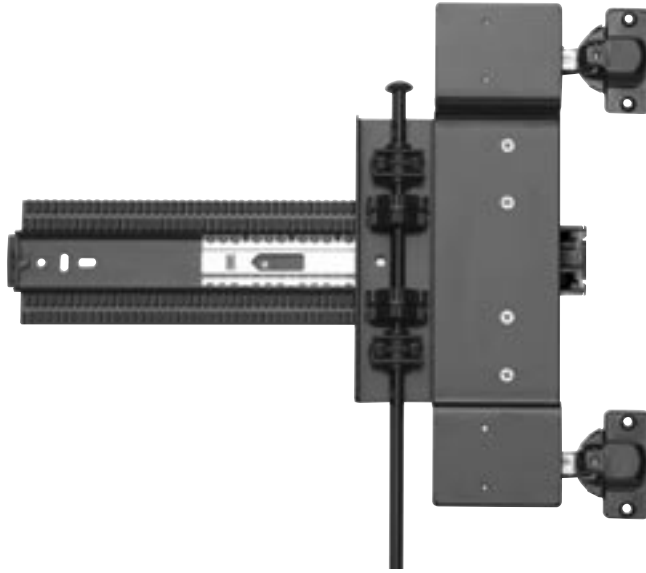


# 4x4 Pocket Door® Full Overlay Kit



| Typical Overlay Applications |          |                   |         |              |          |
|------------------------------|----------|-------------------|---------|--------------|----------|
| Door Thickness               |          | Amount of Overlay |         | Pocket Width |          |
| 3/4"                         | (.7500)  | 3/4"              | (.7500) | 1-3/4"       | (1.7500) |
| 13/16"                       | (.8125)  | 11/16"            | (.6875) | 1-13/16"     | (1.8125) |
| 7/8"                         | (.8750)  | 5/8"              | (.6250) | 1-7/8"       | (1.8750) |
| 15/16"                       | (.9375)  | 9/16"             | (.5625) | 1-15/16"     | (1.9375) |
| 1"                           | (1.0000) | 1/2"              | (.5000) | 2"           | (2.0000) |
| 1-1/16"                      | (1.0625) | 7/16"             | (.4375) | 2-1/16"      | (2.0625) |
| 1-1/8"                       | (1.1250) | 3/8"              | (.3750) | 2-1/8"       | (2.1250) |
| 1-3/16"                      | (1.1875) | 5/16"             | (.3125) | 2-3/16"      | (2.1875) |
| 1-1/4"                       | (1.2500) | 1/4"              | (.2500) | 2-1/4"       | (2.2500) |

## SPECIFICATIONS:

- 75-pound maximum per door.
- Maximum door dimension of 26" wide x 72" high.
- Minimum door height of 24"
- Not recommended for square doors or where door width is greater than door height.
- Self-closing three-way adjustable geometric door hinge with single lever disconnect feature.

# Installation Instructions for KV<sup>®</sup> 4x4 Pocket Door<sup>®</sup> Full Overlay Kit

## READ INSTRUCTIONS FIRST!

These instructions show how to install the KV 8091 Series Pivot Door Slide with overlay kit. Please note that improper installation may void the Knappe & Vogt Limited Lifetime Warranty. To install the slides correctly, follow the enclosed instructions, use only KV hardware and make no modifications. If you have questions or need additional information, please contact Knappe & Vogt customer service.

## Typical Application

- Recommended maximum door dimension: 26" wide x 72" high. For some types of door construction where door center bow may be an issue, a third slide may be used (see fig. 9).
- Minimum door height: 24"
- Maximum door height: 72"
- Recommended maximum door weight: 75 lbs.
- Use recommended KV#8090P CR roller for panel door construction.
- Designed to be used on vertical doors only.

### Step 1. Size the cabinet door

For typical door applications, the cabinet door should be sized to allow for 1/8" top and bottom vertical gap. (see fig. 12)

### Step 2. Install hinge cups in cabinet door

**Always bore on a test block first to verify hinge cup locations.**

Determine location of hinge hole centers. Layout the door cup holes from the top and bottom edges of the door, 2-3/4" from door edge to first hinge cup centerline and 8-13/16" from the centerline of the first hole to the centerline of the second inboard hole (fig. 2). Bore four holes at back inside edge of door following chart recommendations (chart 2) for bore diameter and edge-bore distance. Install hinges in door.

### Step 3. Attach overlay brackets to slides

Use enclosed #8-32 x1/4" screws to attach the overlay brackets to the slider (fig. 4). Note: for proper bracket installation the slide detent needs to be exposed and not covered as shown.

### Step 4. Attach hinge bases to overlay brackets

Use enclosed #8-32 x1/4" screws to attach the hinge bases as shown (figs. 1 & 4).

### Step 5. Position slide channels on partition

Locate the centerlines of the top and bottom slides 7-9/32" from the inside top and bottom surfaces of the partition (see fig. 1). Set back the slides from the front edge of the partition 3/16" (4.8mm) from the front edge of the black molded guide roller on the slide (see fig. 3).

Position the slide channels into the molded rack using the indexing pin on the back of the molded rack through the 1/4" dia. hole on the rear of the slide channel (fig. 5).

Confirm that the slide assemblies are parallel to case edge and then mount the assemblies to the case side by driving screws through the slide assembly.

A mounting screw must always be used in the frontmost slide hole (fig. 6).

Pull slides completely forward so that they are locked out. Note area on partition where hinge adjustment access holes are to be cut. The hinge adjustment access holes size, shape, and location are determined by the maker's preference. Cut access holes.

### Step 6 Prepare pinion shaft and gear assembly

Cut the pinion shaft to 9" less than the overall cabinet opening height. **The shaft end must be clean and deburred to allow the hardware to slide on.** Pre-assemble a pair of pinion gears, pillow blocks and bushings to the top and bottom of the shaft making certain that the gears are assembled with the marking labeled "This side up" facing upward. Insert the pillow block attachment screws into the pillow block to hold the pillow block and bushing assemblies together and then attach the locking cap to the top of the pinion shaft. (fig. 6)

### Step 7 Install pinion gear assembly to slides

Pull the slide hinge brackets to the front of the cabinet so that they are in the locked or detent-out position. Attach the pinion shaft assembly to the slides making sure that the teeth in the gear assemblies line up properly with the teeth in the rack assembly. Tighten the pillow block attachment screws but do not overtighten. (fig. 7)

### Step 8 Install partition.

To determine partition pocket width, use the following formula: Partition Pocket Width = 1" + Door Thickness (See fig. 3)

### Step 9 Hang door and adjust hinges as required

Install hinged cabinet door to slide assembly in partition pocket. For installation ease, each hinge pair must be aligned together to the mating hinge bases and locked down simultaneously. Slowly open and close the door, checking for proper operation and door alignment.

Hinge screws will allow for adjustment of the door in all three directions. (fig. 8)

**Horizontal** adjustment screw—adjusts door side gap clearance. **Do not over adjust—this screw MUST NOT be tight.**

**Depth** adjustment screw—adjusts door face in and out (flush with case edge). **Screw must be tight.**

**Vertical** adjustment screw—adjusts door up and down (top and bottom gap clearance). **Screw must be tight.**

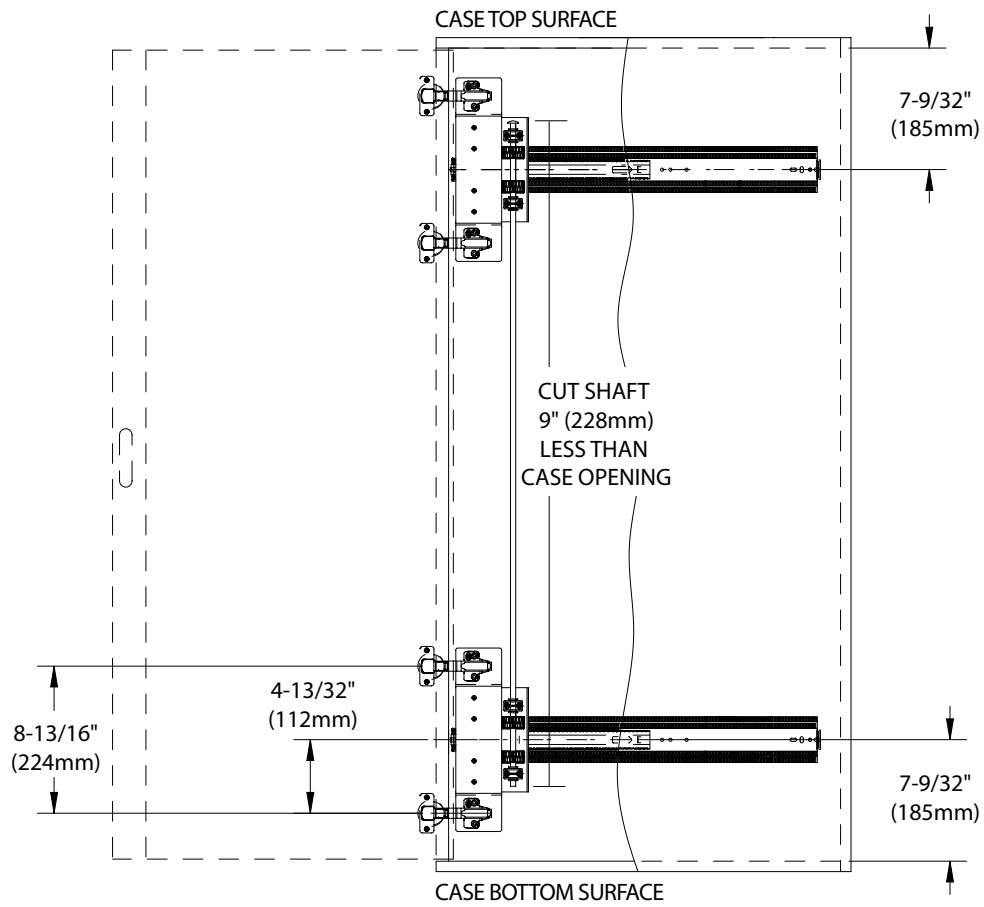
### Step 10 Install guide rollers and felt pads

Secure top and bottom guide rollers using flat-head wood screws supplied. Tighten screws firmly (see fig. 3).

Install felt pads (see fig. 3).

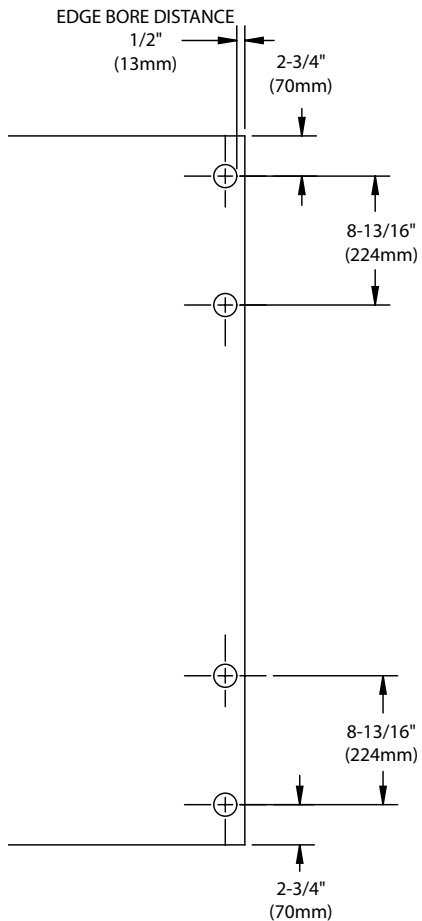
Install cassette roller as needed (see fig. 3).

**figure 1**



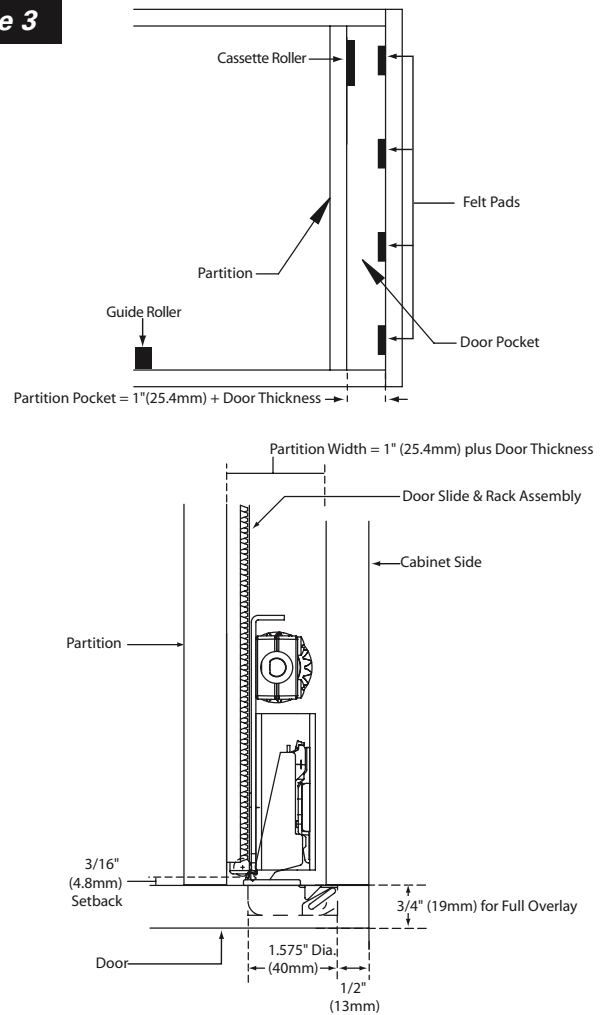
**NOTE:** Not recommended for square doors or where door width is greater than door height.

**figure 2**

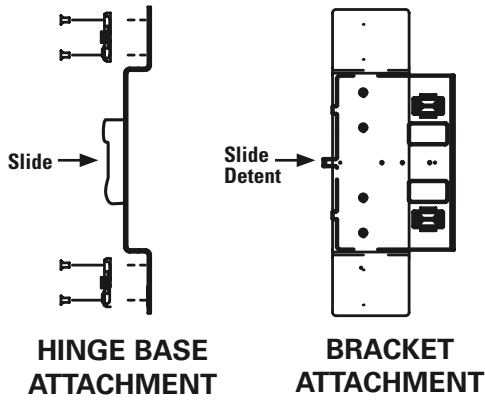


**DOOR PREPARATION**

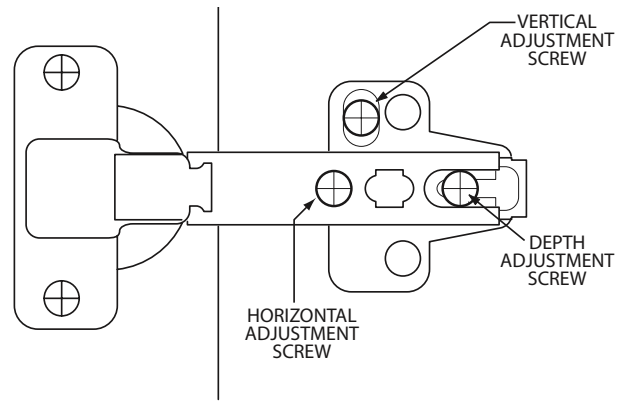
**figure 3**



**figure 4**

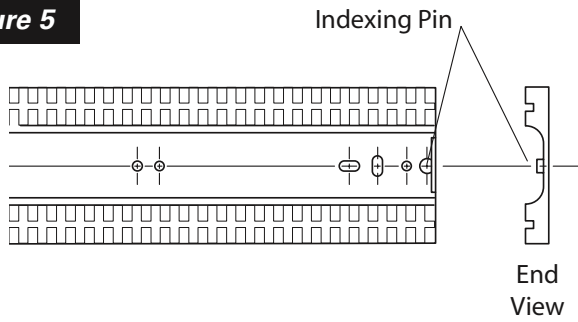


**figure 8**

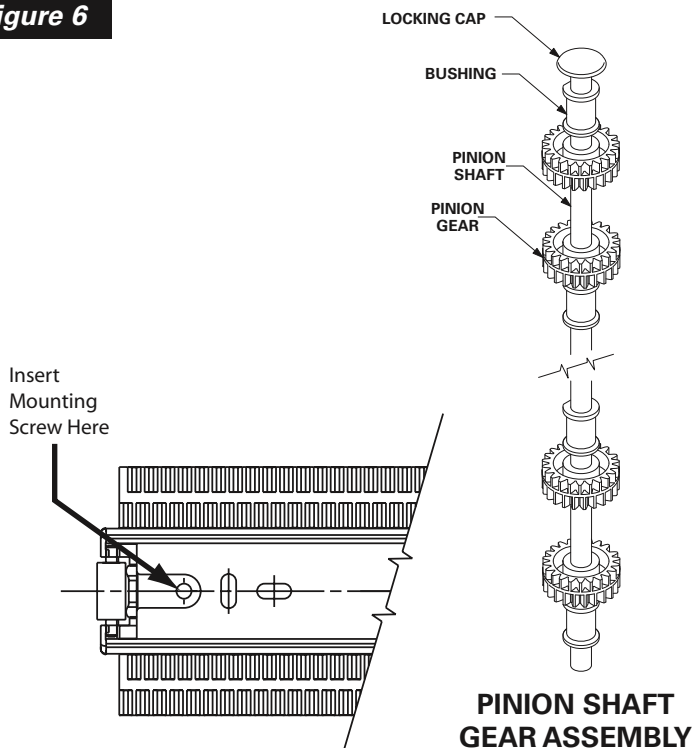


**HINGE ADJUSTMENT**

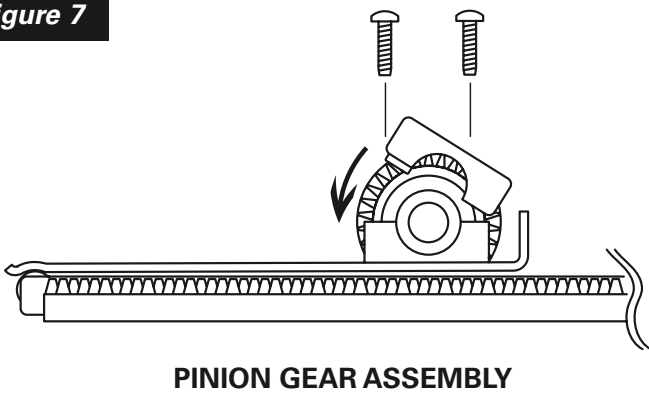
**figure 5**



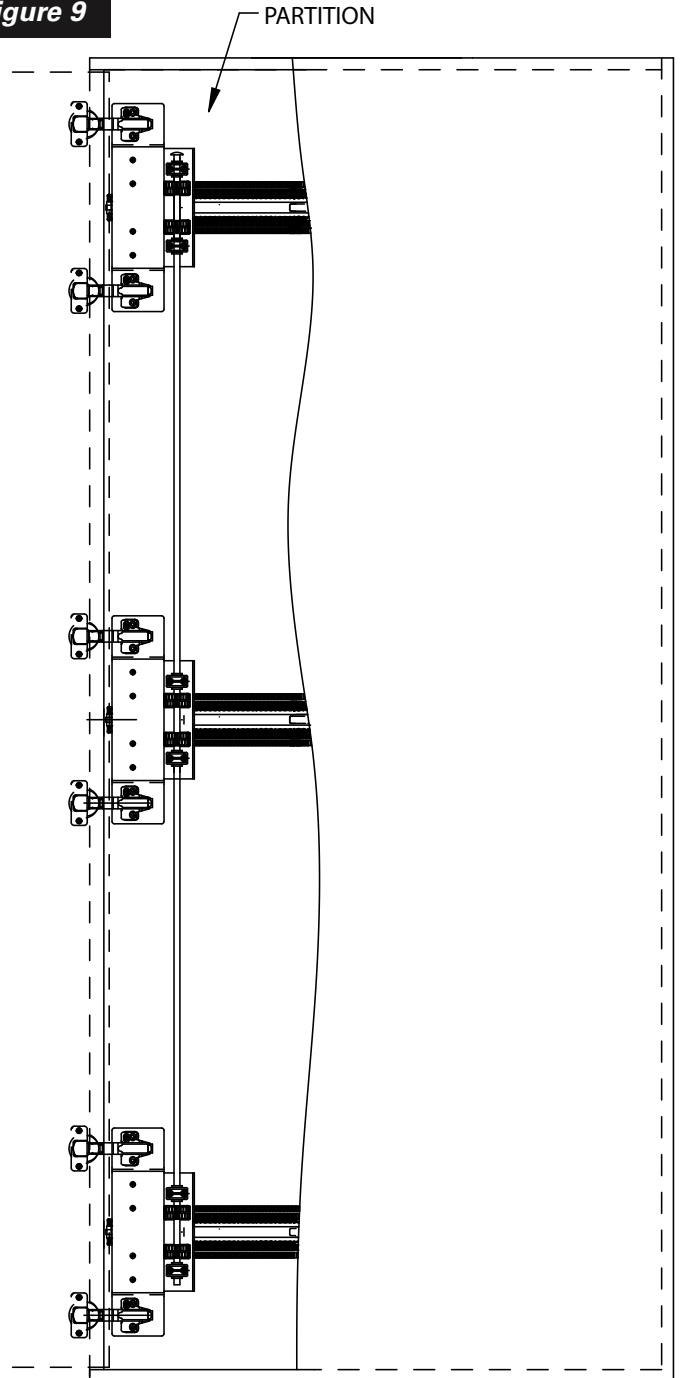
**figure 6**



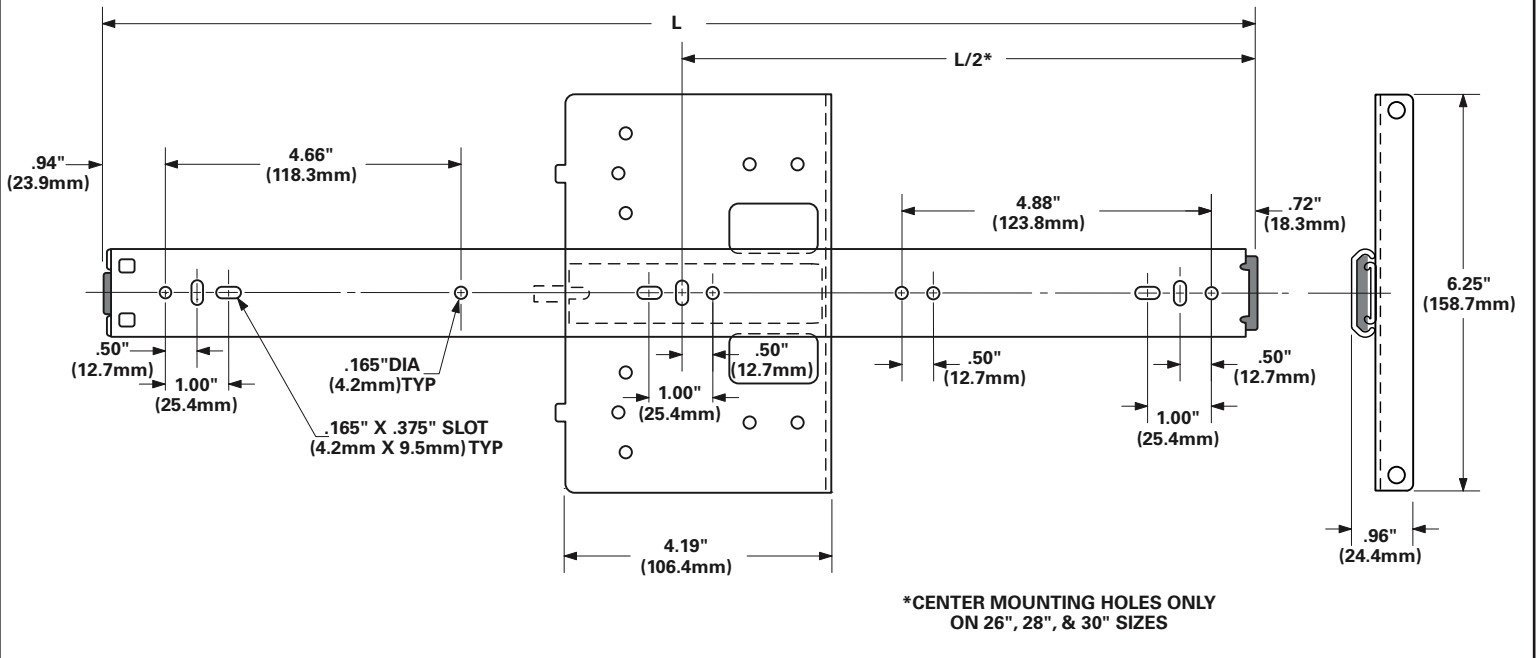
**figure 7**



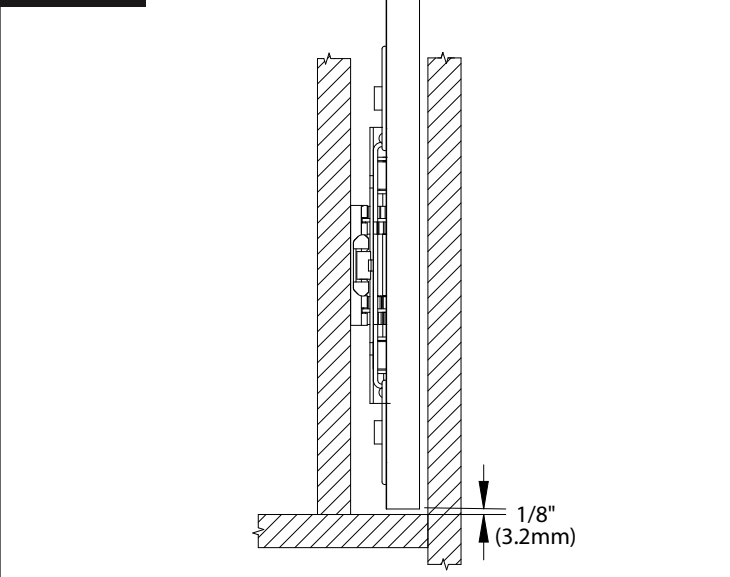
**figure 9**



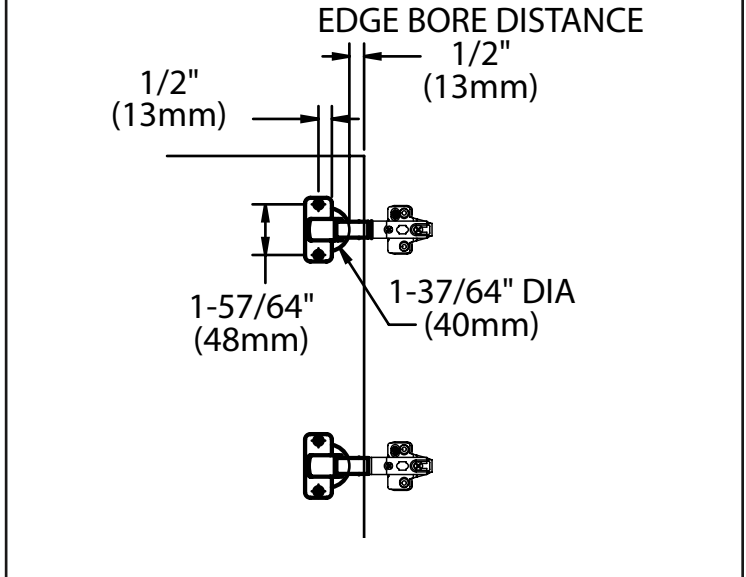
**figure 11**



**figure 12**



**figure 13**



**chart 1**

| Size | L       | L/2*     | Approx. Door Conceal** | Approx. Cabinet Depth*** |
|------|---------|----------|------------------------|--------------------------|
| 12"  | 12-1/8" | -        | 8"                     | 12-3/8"                  |
| 13"  | 13-1/8" | -        | 9"                     | 13-3/8"                  |
| 14"  | 14-1/8" | -        | 10"                    | 14-3/8"                  |
| 15"  | 15-1/8" | -        | 11"                    | 15-3/8"                  |
| 16"  | 16-1/8" | -        | 12"                    | 16-3/8"                  |
| 18"  | 18-1/8" | -        | 14"                    | 18-3/8"                  |
| 20"  | 20-1/8" | -        | 16"                    | 20-3/8"                  |
| 22"  | 22-1/8" | -        | 18"                    | 22-3/8"                  |
| 24"  | 24-1/8" | -        | 20"                    | 24-3/8"                  |
| 26"  | 26-1/8" | 13-1/16" | 22"                    | 26-3/8"                  |
| 28"  | 28-1/8" | 14-1/16" | 24"                    | 28-3/8"                  |
| 30"  | 30-1/8" | 15-1/16" | 26"                    | 30-3/8"                  |

\* Center mounting holes only on 26", 28", & 30" sizes

\*\* Door fully retracted into case

\*\*\* Depth behind inside surface of closed door.

**chart 2**

|                         |                 |
|-------------------------|-----------------|
| Hinge Options           | 8080L           |
| Hinge Description       | Overlay Door    |
| Door Thickness          | 3/4"            |
| Edge Bore Distance*     | 1/2" (13mm)     |
| Hinge Cup Bore Diameter | 1-37/64" (40mm) |
| Hinge Cup Bore Depth    | 13.2mm          |
| Overlay                 | Full            |

\*Edge bore distances shown are approximate. Always bore a test block to verify hinge cup locations.

## Accessories

| Pinion Shaft Options | Description                  | Pack Qty |
|----------------------|------------------------------|----------|
| 8092SB EB 36         | Pinion Shaft 36" Ebony Black | 2        |
| 8092SB EB 48         | Pinion Shaft 48" Ebony Black | 2        |
| 8092SB EB 72         | Pinion Shaft 72" Ebony Black | 2        |
| 8090B EB 36          | Pinion Shaft 36" Ebony Black | 10       |
| 8090B EB 48          | Pinion Shaft 48" Ebony Black | 10       |
| 8090B EB 72          | Pinion Shaft 72" Ebony Black | 10       |

| Cabinet Roller | Description               | Poly Pack Qty | Master Carton Qty. |
|----------------|---------------------------|---------------|--------------------|
| 8090P CR       | Panel Door Cabinet Roller | 1 ea.         | 20 ea.             |

### KNAPE & VOGT LIMITED LIFETIME WARRANTY FOR COMMERCIAL PRODUCTS - USA

This warranty is given to the initial purchaser of new commercial products purchased from Knappe & Vogt Manufacturing Company and its subsidiaries. The warranty covers defects in materials and workmanship. The warranty does not apply to defects resulting from misuse, damage or abuse, normal wear and tear, accident, modification, improper installation or maintenance, third party materials or damage during shipping. The warranty is not transferable and does not cover any subsequent purchasers of the products.

During the Limited Lifetime Warranty period, Knappe & Vogt, will, at its option, repair or replace any defective product with a comparable product or component. This Limited Warranty is for repair or replacement of defective products only and does not cover any other costs such as removal, installation, or other related expenses.

For warranty service, please contact Knappe & Vogt Manufacturing Company, 2700 Oak Industrial Drive, Grand Rapids, MI 49505, Attention: Customer Service. Information regarding the claimed defect and date of purchase of the product must be provided. Any defective product must be returned postage or freight prepaid to Knappe & Vogt.

THIS LIMITED WARRANTY CONSTITUTES THE ONLY WARRANTY FOR THE PRODUCTS AND ALL OTHER WARRANTIES OR REPRESENTATIONS, EXPRESS OR IMPLIED, BY OPERATION OF LAW OR OTHERWISE, INCLUDING BUT NOT LIMITED TO ANY IMPLIED WARRANTY OF MERCHANTABILITY OR FITNESS FOR A PARTICULAR PURPOSE, ARE HEREBY EXPRESSLY DISCLAIMED.

THIS LIMITED WARRANTY CONSTITUTES THE SOLE REMEDY AVAILABLE WITH REGARD TO ANY DEFECTIVE PRODUCTS. KNAPE & VOGT SHALL NOT BE LIABLE FOR ANY INCIDENTAL, INDIRECT, CONSEQUENTIAL OR SPECIAL DAMAGES, INCLUDING WITHOUT LIMITATION, LOSS OF TIME, INCONVENIENCE, OR LOST REVENUES OR PROFITS.



Knappe & Vogt Manufacturing Company  
2700 Oak Industrial Drive NE  
Grand Rapids, MI 49505  
800.253.1561 • 616.459.3311 • fax 616.459.3290  
[www.kv.com](http://www.kv.com)