



Xtend *Monitor Arm*

Knap & Vogt introduces the Xtend monitor arm. Increase your options for monitor arm placement and access with a class-leading 26.0" reach and 13.0" of usable height adjustment. The new Xtend arm also features a pole-less design for optimal space and storage. Its counterbalanced spring technology allows for a 2 to 14 lbs load and provides a longer life for the product by not relying on gas cylinders.

7818 Series

Features & Benefits

Best in class arm provides 26.0" of reach with 13.0" of usable height adjustment.

Visually appealing pole-less monitor arm folds into a 4-3/8" area for more desk space in smaller work environments.

Tool-less clamp installation makes assembly quick and easy.

Flexibility and more options for the end user with a simple, easy-to-use Allen wrench adjustment to counterbalance the weight of the monitor.

With a clamping range of 0" to 2.40" (clamp) that is standard for the Xtend, this new arm will fit to any work surface.

Enclosed cable management system hides cables

Counterbalanced spring technology allows for a 2 to 14 lbs load (no gas leakages from use of gas cylinders)

The arm swivels 360° around the base, increasing the options for display position.

Choice of colors – silver, white or black

Made in USA - BAA compliant. Meets GSA bid requirement.

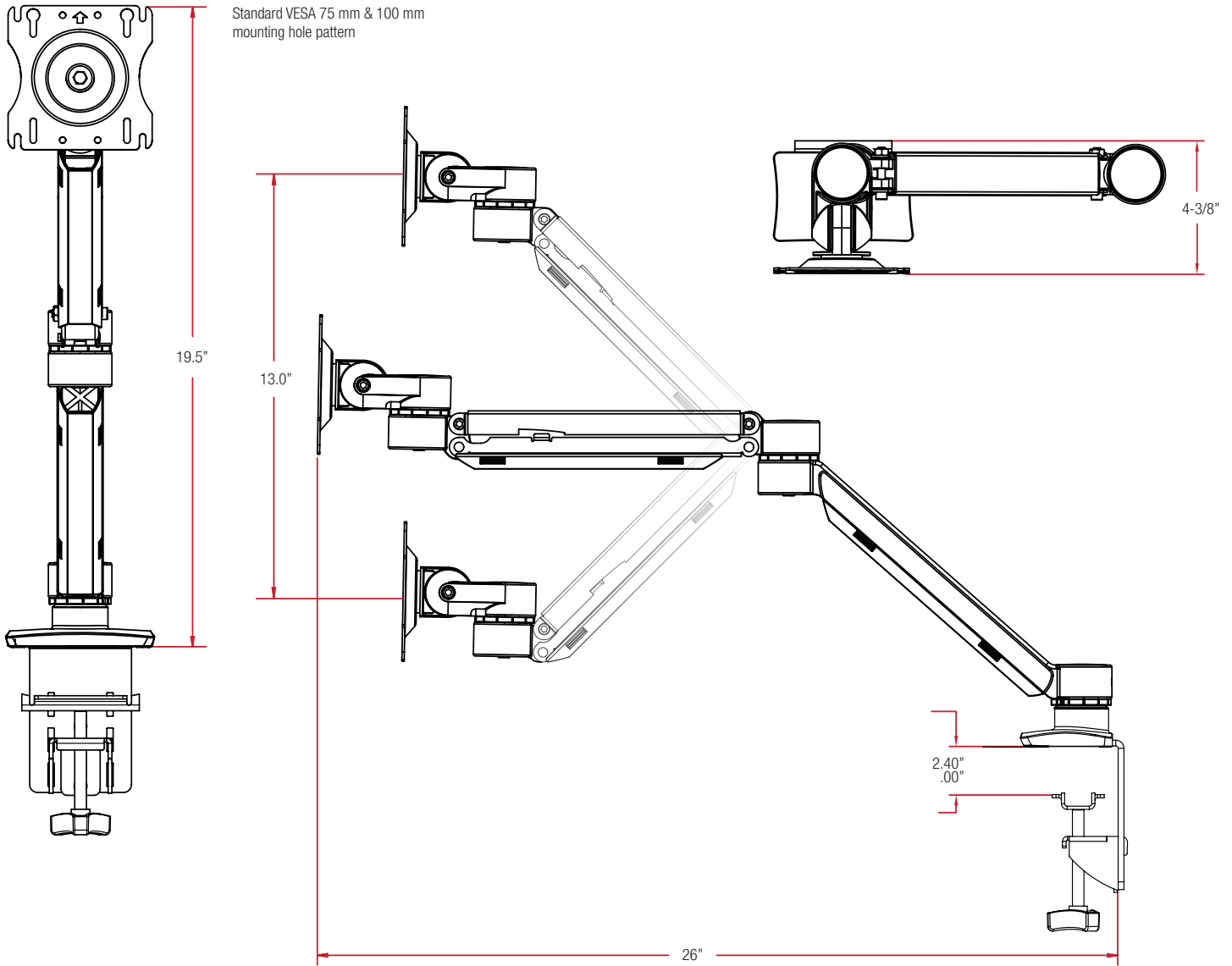

Xtend Monitor Arm 7818 Series

Model	Weight	Description	Pole
7818SJ02	7.8 lbs	Single screen, double extension with one height-adjustable segment	No pole
7818SJ05	7.9 lbs	Single screen, double extension with one height-adjustable segment	4.5"

Color Options

To specify color, other than silver, replace the "S" in the part number with:

B = Black **W** = White

For example, to get a "7818SJ02" in white, order 7818WJ02.



Notes: 1. Weight = packaged shipping weight per unit. 2. Specifications are subject to change without notice.



2700 Oak Industrial Dr. NE
 Grand Rapids, MI 49505-6026 USA
 1.800.253.1561 | 616.459.3311
 Fax: 877.636.3290
www.kv.com

This and other KV literature is available for download at www.kv.com > Resource Library

Knap & Vogt reserves the right to change product specifications at any time without notice and without incurring responsibility for existing units.
 ©2018 Knap & Vogt. KV and the KV logo are trademarks of Knap & Vogt.