

CPU Holders

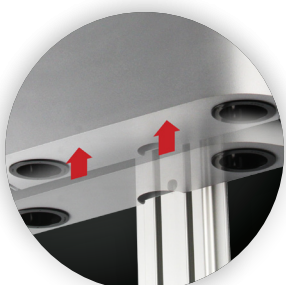

KNAPE & VOGT®

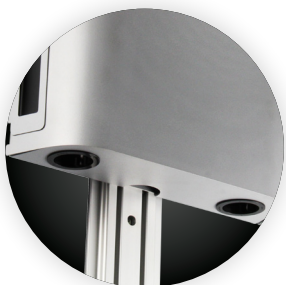

INTELLIGENTLY DESIGNED

- Each unit designed for optimal access and stability measures to ensure equipment remains secure
- Streamline and adjustable to be compatible with the majority of systems on the market

INSTALLS IN MINUTES

- Ships fully assembled resulting in minimal aftersale installation costs and reduced downtime for critical care areas
- Easily installed direct to wall track at any desired position

BUILT FOR LIFE

- Steel composition supports stability and long term dependability
- Maintains high infection control standards with durable anit-microbial agents incorporated into painted surfaces

ACCSTCPU81-S

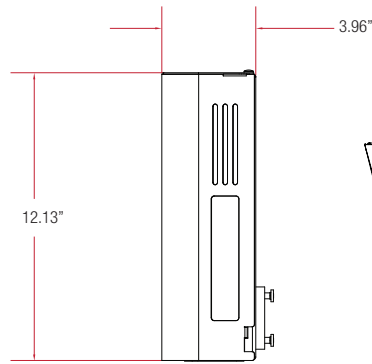
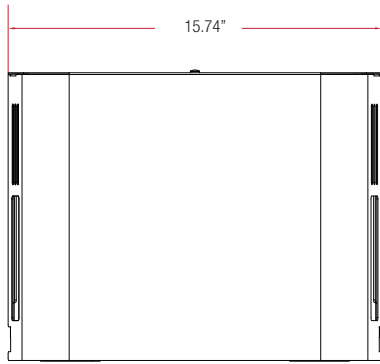

TOP VIEW

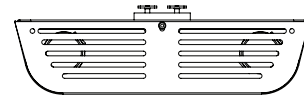

ACCSTCPU61-S

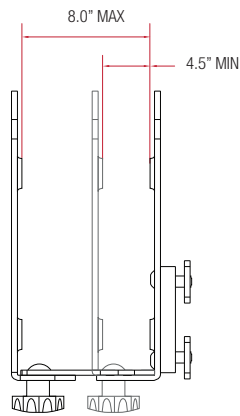
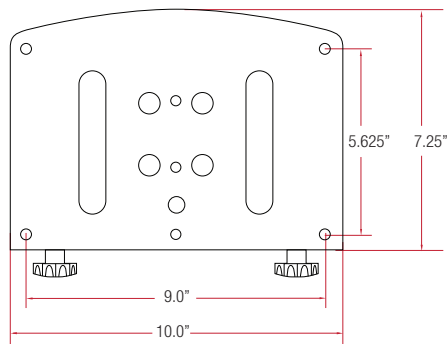

ACCSTCPU51-S

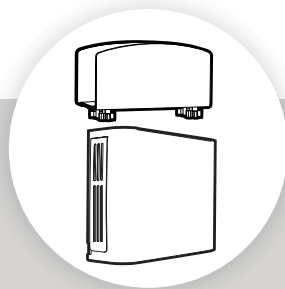
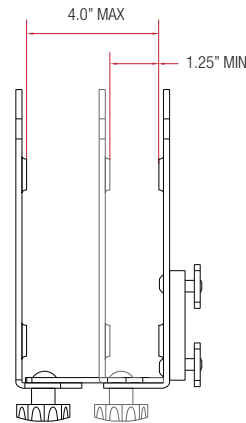
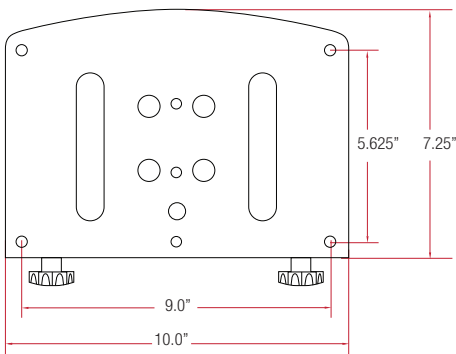

Silver

Finish:



CPU Holders

Model	Width Adjustment	Weight	Storage
ACCSTCPU81-S	4-5.5"	14 lbs.	Fixed
Shipping weight: 14 lbs. Box dimensions: 21" x 17" x 11"			
ACCSTCPU61-S	4.5-8"	8 lbs.	Fixed
Shipping weight: 7 lbs. Box dimensions: 5" x 9" x 13"			
ACCSTCPU51-S	1.25-4"	7 lbs.	Fixed
Shipping weight: 7 lbs. Box dimensions: 5" x 9" x 13"			



2700 Oak Industrial Dr. NE
Grand Rapids, MI 49505-6026 USA
1.800.253.1561 | 616.459.3311
Fax: 877.636.3290
www.kv.com

Knapé & Vogt Waterloo - 501 Manitou Drive,
Kitchener Ontario, Canada N2C 1L2
1.866.521.8028 | 1.519.748.5060
Fax 519.748.4783
www.healthcare.kv.com

OL2534/0314