

Dual Stud Spanning Wall Track



Intelligently Designed

- Allows for optimal location placement
- Dual contact points ensure product remains securely attached
- Use in conjunction with any Fluid™ or CX configuration

Installs in Minutes

- Installed on external surfaces, omits the need to cut into wall for backing or structural supports
- Quick connecting components ensure effortless and simple installation
- Toggler hardware is provided for convenience

Built for Life

- Designed for long term durability maximizing return on investment
- Modular in design and assembly to easily accommodate fluctuations in requirements
- Manufactured of anodized aluminum and steel which supports high performance, and long term use

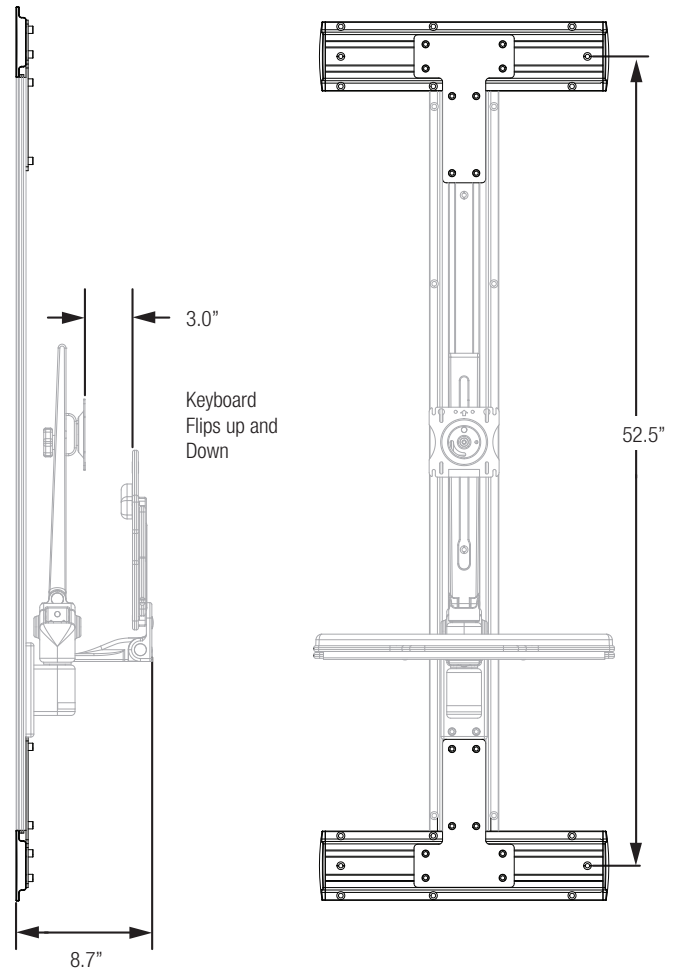
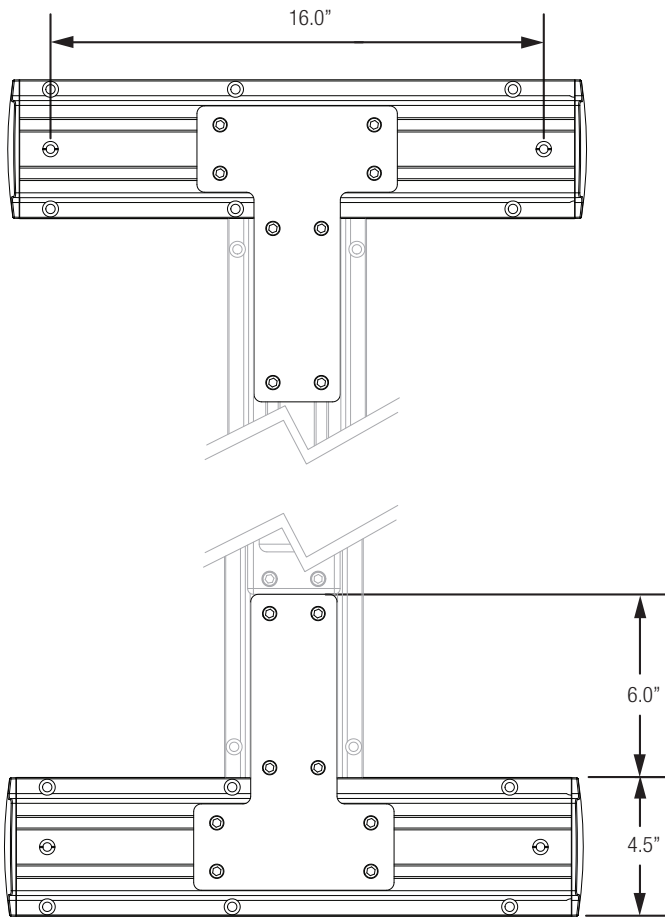

Accessories

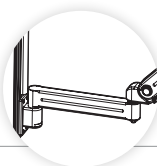

16" Extension Arm

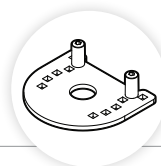

Fluid Limiter

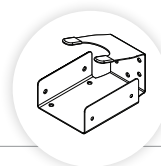

Scanner Holder

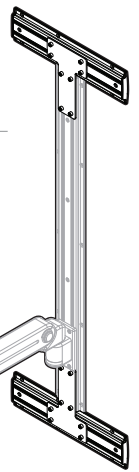

Dual Stud Spanning Wall Track

| Model | OPM# | Width | Height | Distance Between Mounting Holes | Finish |
|--------|------|-------|--------|---------------------------------|--------|
| 11113S | 1811 | 18.0" | 10.5" | 16.0" | Silver |

Shipping weight: 10 lbs. Box dimensions: 18" x 10-3/8" x 2-3/8"

NOTE: The Dual Stud Spanning Wall Track is an accessory item only used in conjunction with all Fluid™ configurations and is purchased separately.

*All dimensions are in inches for reference only.



2700 Oak Industrial Dr. NE
 Grand Rapids, MI 49505-6026 USA
 1.800.253.1561 | 616.459.3311
 Fax: 877.636.3290
www.kv.com

This and other KV literature is available for download at www.kv.com > Resource Library

Knappe & Vogt reserves the right to change product specifications at any time without notice and without incurring responsibility for existing units.
 ©2015 Knappe & Vogt. KV and the KV logo are trademarks of Knappe & Vogt.