

41SS Server Rack Slide with Cable Management



KNAPE & VOGT.

When it comes to sourcing slides for IT server racks, Knape & Vogt can help you surpass all customer expectations. A trusted partner with top teams in the industry, KV delivers sliding systems, engineering expertise and practical manufacturing know-how to OEMs and contract manufacturers worldwide.

Our experts will work side-by-side with yours to create optimal designs based on our 41SS Server Rack Slide series, with tool-less installation, built-in cable management and sought-after features that provide smooth, easy access to data storage, servers and subsystems that is critical for successful storage and maximizing uptime.

Application

1U and 2U Server Racks

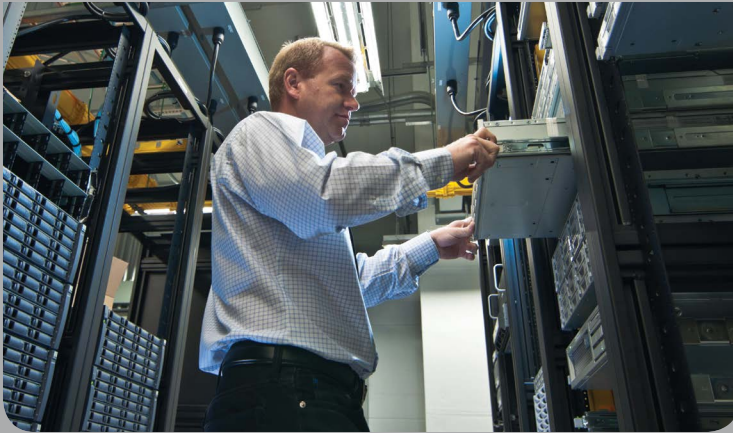

11 Models

Number	Description	Length
41SS-24 CMA	41mm Server Slide with CMA	24"
41SS-26 CMA	41mm Server Slide with CMA	26"
41SS-28 CMA	41mm Server Slide with CMA	28"
41SS-30 CMA	41mm Server Slide with CMA	30"
41SS-32 CMA	41mm Server Slide with CMA	32"
41SS-24	41mm Server Slide (CMA compatible)	24"
41SS-26	41mm Server Slide (CMA compatible)	26"
41SS-28	41mm Server Slide (CMA compatible)	28"
41SS-30	41mm Server Slide (CMA compatible)	30"
41SS-32	41mm Server Slide (CMA compatible)	32"
SS-CMA	Cable Management Accessory (CMA)	

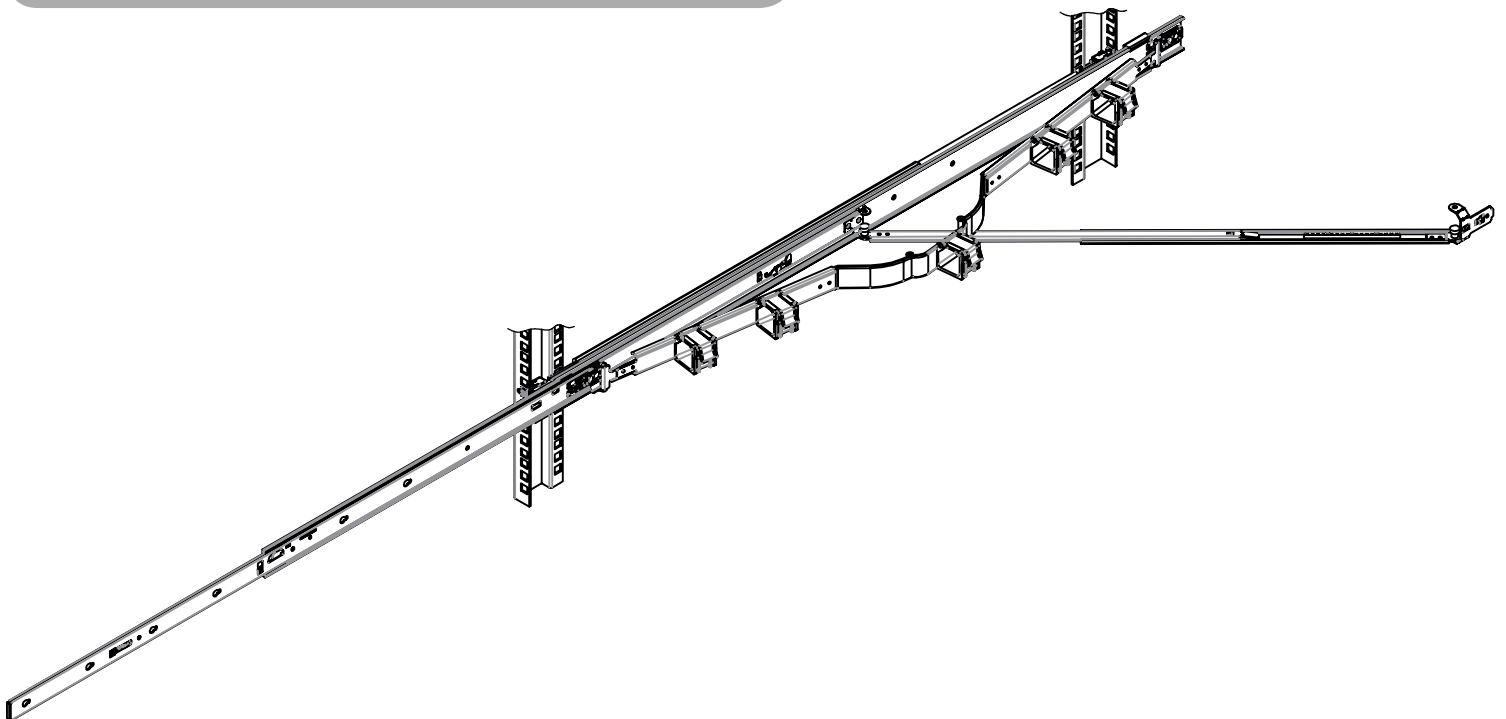

Features & Benefits

The 41SS is KV's solution for 1U and 2U server applications. Featuring an ultra-slim width to maximize server chassis space, the 41SS supports dynamic loads up to 88 lbs. (40kg) and static loads up to 209 lbs. (95kg).

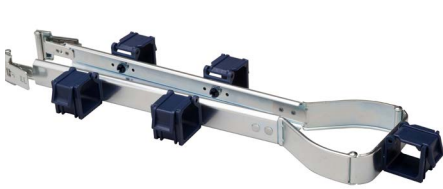

Cable Management Accessory

The 41SS Cable Management Accessory (CMA) is included with some models or available separately. Lightweight and expandable to move with the slide, the CMA features a quick-release connector for easy tool-less connecting and disconnecting. It includes a separate snap-on 19mm slide support that attaches to the rear of the slide on either side of the chassis for added stability and alignment.



CMA Cable Carrier

The Cable Management Accessory supports up to 13 lbs. (6kg) of cabling and features five polymer cable carriers with navy finish. The carriers easily snap open or closed and rotate 360° to position them for right-hand or left-hand use.



CMA Quick Release

The Cable Management Accessory features a quick release mechanism at the rear of the assembly for quick and easy connecting and disconnecting without tools.



Universal, Tool-less Bracket

The mounting bracket provides tool-less installation with round or square mounting holes.



Ball Retainer Lock

A ball-bearing retainer lock holds the retainer in place for easy installation of the inner slide member.



Disconnect/Lock Release Lever

A lock release lever allows the server chassis to be easily removed from server rack for easy servicing of components.

Other Features

Dynamic Load Rating

88 lbs. (40kg)

UL Static Load Rating

Up to 209 lbs. (95kg)

RoHS Compliant

Zinc finish

Travel Options

- 3/4 extension
- Full extension
- Over travel 1"-3"

Unhanded Design

For ease of installation

41SS Technical Information

Specifications

Number	Description	Length
41SS-24 CMA	41mm Server Slide with CMA	24"
41SS-26 CMA	41mm Server Slide with CMA	26"
41SS-28 CMA	41mm Server Slide with CMA	28"
41SS-30 CMA	41mm Server Slide with CMA	30"
41SS-32 CMA	41mm Server Slide with CMA	32"
41SS-24	41mm Server Slide (CMA compatible)	24"
41SS-26	41mm Server Slide (CMA compatible)	26"
41SS-28	41mm Server Slide (CMA compatible)	28"
41SS-30	41mm Server Slide (CMA compatible)	30"
41SS-32	41mm Server Slide (CMA compatible)	32"
SS-CMA	Cable Management Accessory (CMA)	

Mounting	Side
Dynamic Load	88 lbs. (40kg)
UL Static Load	Up to 209 lbs. (95kg)
Height	41mm (1.6")
Finish	Zinc
Action	Telescopic movement on precision steel ball bearings
Additional Features	<ul style="list-style-type: none"> • Ultra Slim Width maximizes server chassis space • Universal Tool-Less Bracket for round or square holes • Ball Retainer Lock for ease of installing inner member • Disconnect/Lock Release Lever for easy chassis removal • Cable Management Accessory with Quick Release • Cable Management Cable Holder • Unhanded • Over Travel
Packaged	1 carton = 1 set

Dimensions

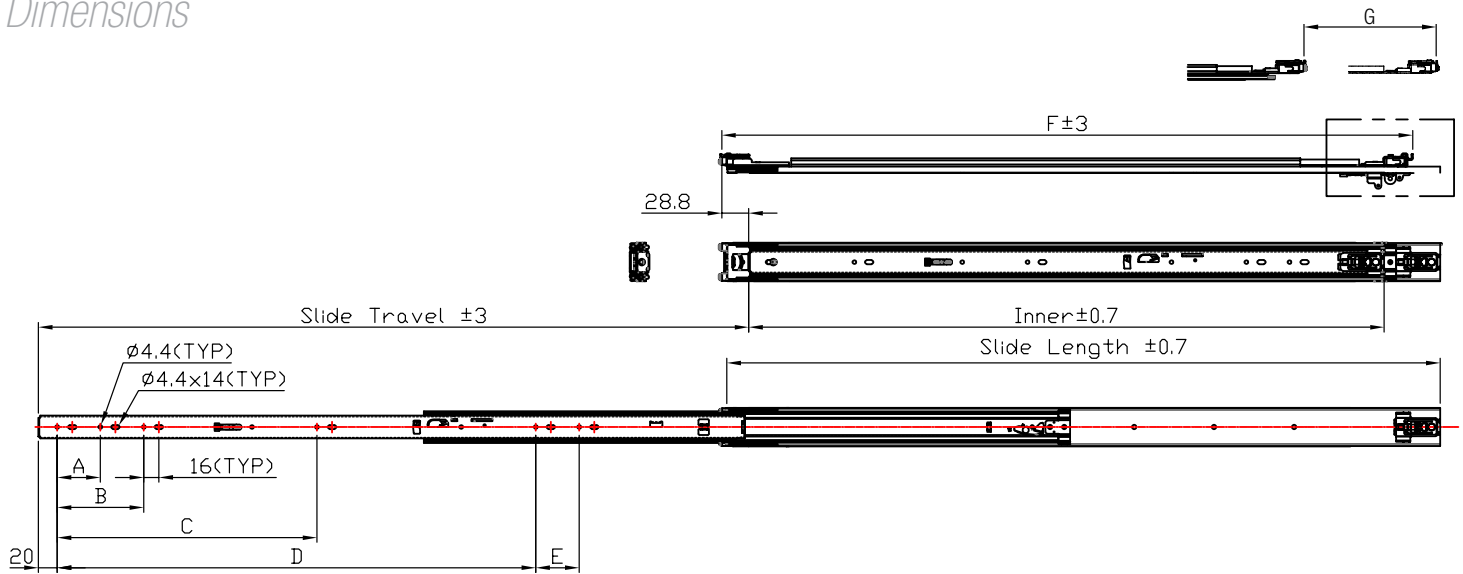

SKU Number	Size	Slide Length	Slide Travel	A	B	C	D	E	F	G
41SS-24	24"	25" [633mm]	18" [468mm]			230.2	369		645	280
41SS-24 CMA	[610mm]									
41SS-26	26"	27" [683mm]	21" [523mm]			230.2	409		695	280
41SS-26 CMA	[660mm]									
41SS-28	28"	29" [733mm]	23" [573mm]	46.1		276.3	458		745	365
41SS-28 CMA	[711mm]									
41SS-30	30"	31" [783mm]	25" [623mm]	46.1	92.1	276.3	458	46.1	775	365
41SS-30 CMA	[762mm]									
41SS-32	32"	33" [833mm]	27" [673mm]	46.1	92.1	304.8	509	46.1	775	365
41SS-32 CMA	[813mm]									

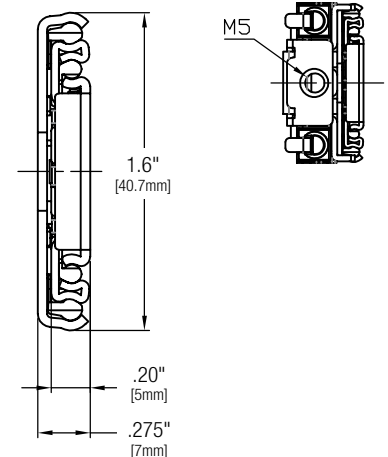

KNAPE & VOGT

2700 Oak Industrial Dr. NE
Grand Rapids, MI 49505-6026 USA
1.800.253.1561 | 616.459.3311
Fax: 877.636.3290
www.kv.com

This and other KV literature is available for download at www.kv.com > Resource Library

Knap & Vogt reserves the right to change product specifications at any time without notice and without incurring responsibility for existing units.
©2016 Knap & Vogt. KV and the KV logo are trademarks of Knap & Vogt.

OL2878/1016